

# Model SPVRB

## Three Phase Voltage Monitor

### Standard Features

- Phase Unbalance: 8 %
- Adjustable Trip Delay 1 to 10 seconds after failure occurs.
- Output Relay: normally de-energized: Form C contacts for easy circuit configuration.
- Electro - Mechanical Indicator: retains memory of fault until manually reset.
- Door or Panel mounting.
- Status Indicator: Bi-colored LED  
Green: Output Relay De-energized (Normal Condition)  
Red: Output Relay Energized (Fault Condition)  
Dark: Output relay De energized (Input Power Off).
- Single Phase, Phase Reversal, Phase Unbalance and Phase Loss Protection: Operates the output relay after a preselected time.
- Automatic or Manual mode: Automatic mode: Upon removal of fault conditions, relay automatically resets to normal. Manual mode: Upon removal of fault conditions, relay resets to normal after local/remote reset button has been pressed.

The Model SPVRB Voltage Sensing Relay is designed to protect against single phase, phase loss, phase unbalance, phase reversal, and under or over voltage in a power system. The output contacts change their normal state only when a phase loss, phase unbalance, phase reversal, occurs for longer than the preset trip delay. A total power loss de-energization of the SPVRB relay will not change the output contact position. Recommended for manually reset switches and breakers applications. The SPVRB is suitable for loss of phase with motor loads.

### Application

Protection of three phase electric equipment sensitive to damage from a phase loss or phase unbalance. Phase reversal, phase sequence.

### Normal Input Voltages

120 to 600 Vac, 60 Hz., 380 to 415 Vac, 50 Hz.

### Ambient Temperature Range

Operation: - 30 °C to +60 °C.  
Storage - 40 °C to +85 °C.  
Terminals screws are #6-32 nickel plated brass.  
Shipping weight 2.0 lbs

### SPVRB

| Model Number | Nominal Vac | Hz. |
|--------------|-------------|-----|
| SPVRB-120    | 120         | 60  |
| SPVRB-208    | 208         | 60  |
| SPVRB-240    | 240         | 60  |
| SPVRB-480    | 480         | 60  |
| SPVRB-575    | 575         | 60  |
| SPVRB-380    | 380         | 50  |
| SPVRB-415    | 415         | 50  |

### Typical Wiring Diagram

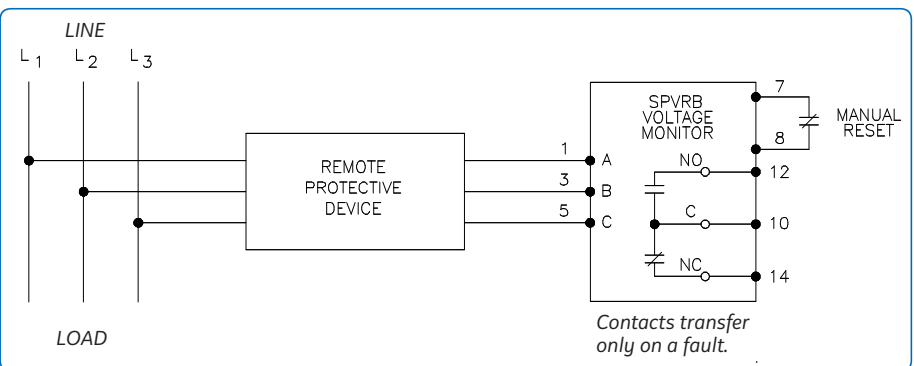

### REGULATORY AGENCY APPROVALS



103039, CANADIAN



103039

### Contact Rating

|                           |
|---------------------------|
| 10 A, 1/3 H.P. AT 120 VAC |
| 10 A, 1/2 H.P. AT 240 VAC |
| 3 A, 1/2 H.P. AT 600 VAC  |

### How to order Relays

#### SPVRB - XXX

Input Voltage  
120, 208, 240, or 575 Vac (60 Hz)  
380 or 415 Vac (50 Hz)



## SPVRB Dimensions

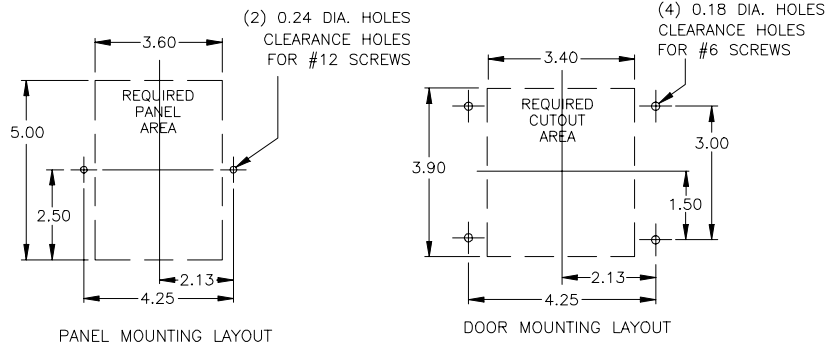
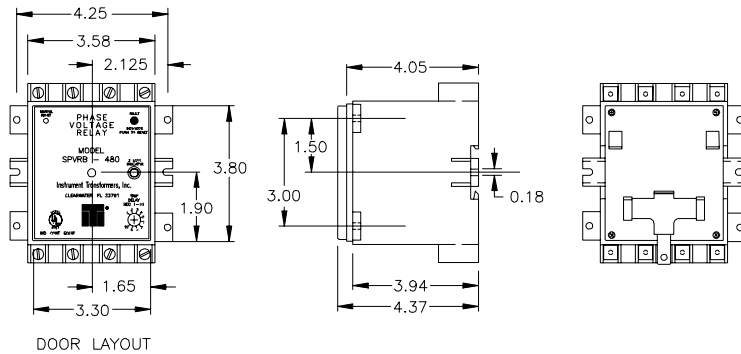

## SPVRB Operation with Options

A correctly installed SPVRB Voltage Sensing Relay will protect a power system against damage due to single phase and phase loss, phase reversal, phase unbalance. When operating under normal power conditions, the bi-colored LED "Relay Status" will be green indicating the de-energized state of the output relay.

If a single phase, phase sequence, phase reversal, phase loss or unbalance of 8% occurs for longer than the preselected time delay of 1 to 10 seconds, the output relay is energized and changes state. Whenever the output relay contacts are energized indicating a fault, the bi-colored LED "Relay Status" will be red.

In automatic mode (no connection between 7 & 8), the relay automatically resets when power is restored.

In manual mode (jumper or N/C contact placed between 7 & 8) when power is restored, the relay does not reset until either the manual reset button has been pushed or the N/C contact has been opened and reclosed. The manual reset button is on the front of the relay.

The output relay has single Form C contact.

The SPVRB relay is package is in a high impact thermoplastic enclosed which can be either panel or door mounted. The terminal hardware is set for panel or door mounted. The terminal hardware is set for panel mounting but is easily reversed for door mounting. A clear cover is provided to prevent accidental mechanical indicator changes.



1. ELECTROMECHANICAL DIAGNOSTIC INDICATOR  
Phase Loss.
2. BI-Colored LED INDICATOR  
Power system condition.  
Normal (green)  
Trip (red).
3. ADJUSTABLE SYSTEM DELAY:  
Single phase.  
Phase loss.  
Phase unbalance  
Phase reversal

## GEGridSolutions.com

ITL\_Model\_SPVRB-Spec-EN-2020-02-Grid-PQP-1583. © Copyright 2020. General Electric Company and Instrument Transformers LLC reserve the right to change specifications of described products at any time without notice and without obligation to notify any person of such changes.

### Worldwide Contact Center

Web: [www.GEGridSolutions.com/contact](http://www.GEGridSolutions.com/contact)

Phone: +44 (0) 1785 250 070

USA and Canada: +1 (0) 800 547 8629

Europe, Middle East and Africa: +34 (0) 94 485 88 00

