

# Model JWV-4A SUPERBUTE™

**Outdoor Voltage Transformer**  
**2,400 V to 7,200 V, 60 Hz, 75 kV BIL**

## Application

Model JWV-4A is a high accuracy voltage transformer designed for outdoor service. This model will meet IEEE C57.13.6 0.15 high accuracy class from OVA through the specified standard burden, from 90 % to 110 % of the rated voltage and is suitable for operating meters, instruments, relays, and control devices. This model is available in a variety of voltage, ratio and bushing types as outlined in the unit selection table below. Additional designs are available upon request. Rated Station Class with higher burden, thermal rating, and creep distance.

## Features

- Thermal Rating: 2,000 VA (55 °C rise above 30 °C)
- Weight: 105 lbs (unit), 120 lbs (shipping)
- Dimensions: 16.88" (h) x 14.25" (w) x 13.05" (d)
- Creep Distance: 20.38" [517.7 mm]
- Strike Distance: 12" [305 mm]
- Insulation: HY-BUTE 60™ Butyl Rubber
- Insulation Class: 75 kV BIL, Outdoor
- Primary Winding Style: Lattice-Type
- Design Standard: IEEE C57.13
- Measurement Canada Approval: AE-2027



## JWV-4A Unit Selection

Rated Primary Voltage	Ratio	IEEE Accuracy Class, 60 Hz Burden <sup>1</sup>	Catalog Number
<b>Double-Bushing<sup>2</sup></b>			
2,400/4,160Y	20:1	0.15 W, X, M, Y	764X031011
4,200/7,280Y	35:1	0.15 W, X, M, Y	764X031012
4,800/8,320Y	40:1	0.15 W, X, M, Y	764X031013
7,200/7,200Y	60:1	0.15 W, X, M, Y	764X031014

1. Voltage transformers of this type are available for use in 50 Hz applications for many ratings. However, IEEE C57.13 to which these transformers were designed and tested to does not apply to 50 Hz. When ordering voltage transformers for 50 Hz applications, provide an accuracy specification including Burden VA and Power Factor. If not specified, the transformer(s) will be tested per standard 60 Hz test burdens.

2. Double bushing voltage transformers are suitable for operating line-to-line, line-to-ground or line-to neutral at a reduced voltage. The primary voltage under line-to-ground operation is the line-to-line voltage divided by  $\sqrt{3}$ , or approximately 58%. Contact GE for accuracy rating at reduced operating voltage.



### Wiring Diagrams

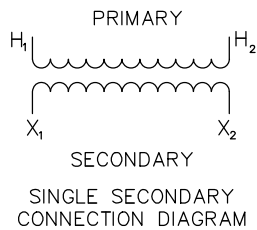

### Typical Nameplate

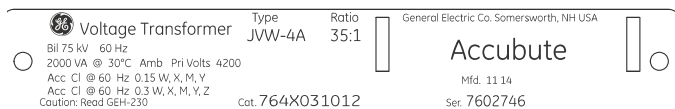

### Reference Drawings & Accessories

#### Reference Drawings

- Accuracy Curve at 120 Secondary Volts, 60 Hz - 9932600132
- Excitation Curve - 9932600134
- Outline Drawing - 9933030

#### Accessories

- "L" Mounting Brackets - 8944634002
- Channel Bracket - 5466227001
- Suspensions Hooks - 8944630001
- Secondary Conduit Box - 9689897001

### JVW-4A Selection Guide

Product Class	8.7 KV	15 KV	25 KV	35 KV	46 KV	69 KV
<b>Station Class</b>	<b>JVW-4A</b>	<b>JVW-5A</b>	<b>JVS-150A</b>	<b>JVS-200A</b>	<b>JVS-250A</b>	<b>JVS-350A</b>
			<b>JVT-150A</b>	<b>JVT-200A</b>	<b>JVT-250A</b>	<b>JVT-350A</b>
BIL	75 kV BIL	110 kV BIL	150 kV BIL	200 kV BIL	250 kV BIL	350 kV BIL
Accuracy, kVA Rating	0.15 Y, 2 kVA	0.15 Y, 2 kVA	0.15Z, 3 kVA	0.15 Z, 3 kVA	0.15 Z, 4.5-5 kVA	0.15 Z, 4.5-5 kVA
Creep Distance	20.4" Creep	20.4" Creep	27-27.5" Creep	35-36" Creep	48-50" Creep	64-66" Creep
Net Weight	105 lbs	105 lbs	225-230 lbs	235-240 lbs	420 - 520 lbs	430-560 lbs
<b>Distribution Class</b>			<b>JVW-6A</b>	<b>JVW-7A</b>		
BIL			125-150 kV BIL	150-200 kV BIL		
Accuracy, kVA Rating			0.15 X, 0.75 kVA	0.15X, 0.75 kVA		
Creep Distance			21" Creep	26.5" Creep		
Net Weight			105 lbs	140 lbs		

### Two Bushing Dimension Drawing

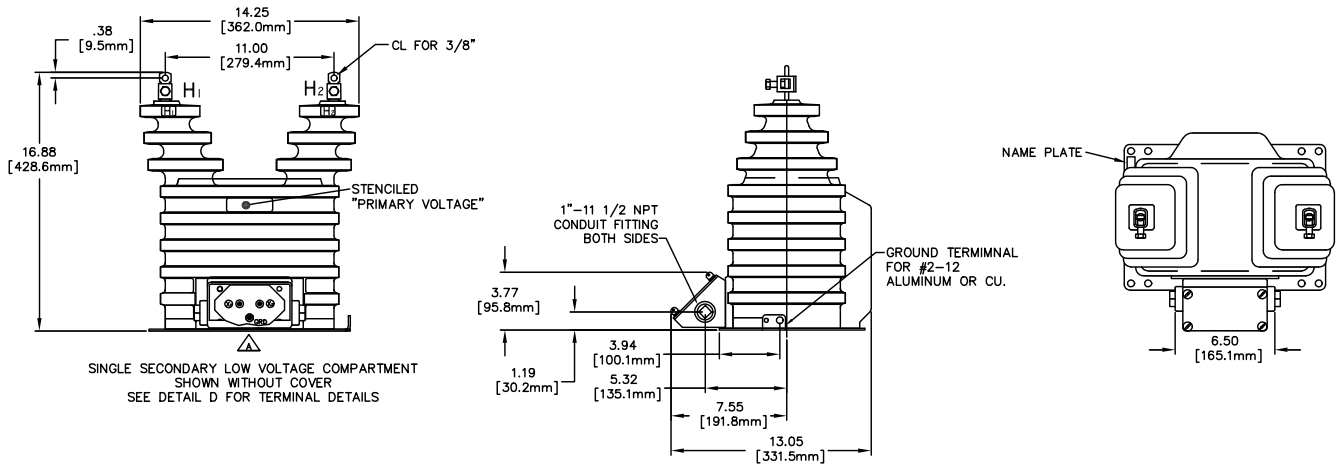

### Mounting Plate Drawing

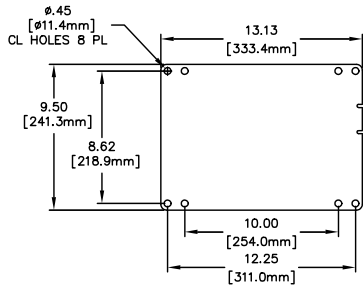

### Secondary Terminal Configuration

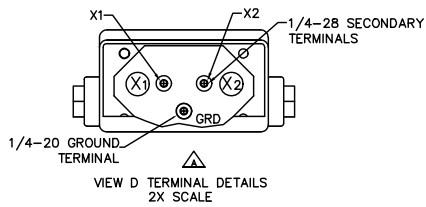

## Construction Details

### Insulation

The transformer design is constructed using GE's premium HY-BUTE 60 molded butyl rubber insulation for the transformer body. First introduced in 1955, GE's unique formulation is non-arc tracking and resistant to heat, chemicals, ozone and ultraviolet. This tough, resilient insulating material has proven to be superior in handling mechanical, electrical and environmental extremes, when compared against other insulation designs such as porcelain, urethane or epoxy.

### Core & Coil

The internal primary windings are constructed with a LATTICE-type primary winding, originally patented by GE. The lattice-type design better distributes voltage stress across the windings, minimizes partial discharge, and maintains higher accuracy across the load range as compared to a traditional layer wound primary design. Outer electrostatic faraday shields act to further distribute steep voltage fronts across the coils. The finished primary coil is precast in epoxy resin prior to being molded in the outer HY-BUTE™ 60 insulation, for additional dielectric and mechanical strength. The core is made of high-quality silicon steel which is carefully selected, tested and annealed under rigidly controlled factory conditions. Enamel-insulated wire is used in both the primary and secondary coils.

### Primary Terminals

The primary terminals are of the solder-less type. Made of hardened bronze, the terminal is fitted with a hard-copper collar and bronze pressure screw. The collar is semi-captive and may be turned 90-degrees in either direction for vertical or horizontal connection. With the collar in the vertical position, the maximum conductor sizes for copper are 250MCM and aluminum is 4/0. With the collar in the horizontal position, the maximum conductor sizes for copper are 3/0 and aluminum is 2/0. In either position, the minimum conductor size is AWG 10. A clearance hole for a 3/8 inch bolt is provided in the top of the terminal for additional flexibility in making connections. The complete terminal assembly is heavily electroplated with tin so that it is suitable for outdoor use.

### Secondary Terminals

The secondary terminals are located on the insulated surface adjacent to the baseplate. These terminals are clamp-type in fixed, round tin-plated bronze posts, with excellent durability and corrosion resistance. They have a 0.275 inch diameter cross hole to accommodate large or multiple secondary wires. The secondary terminals are molded in the insulation and held in place internally by a terminal block that prevents their rotation.

### Testing

Rigorous GE test requirements meet and exceed IEEE C57.13 routine requirements in order to ensure long term reliability. Test reports are saved electronically and can be e-mailed in various formats upon request.

### Ground Terminal

A ground terminal is provided in the secondary compartment for making an optional connection to one of the secondary terminals. The 1/4-20 roundhead ground terminal is welded in the baseplate bracket, and is furnished with a nut, cup washer, flat washer, and lock washer.

### Conduit Box

A detachable secondary conduit box is provided with the transformer. This die-cast aluminum conduit box is furnished attached to the transformer. Its use permits easy change out of transformers without dismantling rigid conduit structures. The box is provided with two 1 inch threaded conduit hubs on the sides and a 1 inch conduit knockout in the bottom. Each box is furnished complete with aluminum cover, gasket, four sealable cover screws, seal wire, four mounting screws with lock washers, and plastic pipe plugs.

### Polarity

The permanently molded primary polarity markings H1 and H2 and the secondary polarity markings X1 and X2 are situated adjacent to their respective terminals. The polarity terminal is designated by use of the subscript 1, and the mark is painted white for better visibility.

### Baseplate and Mounting

The base is made of stainless-steel. A stainless-steel grounding lug is welded to the baseplate and provides a hole for attaching the grounding connector. Mounting holes or slots are located in each corner of the baseplate. Mounting hardware is supplied with the transformer. The transformer can be mounted with the primary terminals in any position—up, down, or horizontal. It can be bolted directly to a cross-arm attached by "U" bolts or suspension hooks, or mounted on double cross-arms, using channel brackets.

### Nameplate

The nameplate is made of stainless-steel and located on the base of the transformer. Information is per IEEE designation, laser-engraved for easy-to-read form. Custom barcoding available upon request.

### Rating Identification

The high-voltage rating is identified by large orange digits located on the insulation surface near the top of the transformer. This provides permanent identification that is clearly visible from a distance, and is resistant to fading and abrasion.

### Maintenance

These transformers require no maintenance other than an occasional cleaning if installed in an area where air contamination is severe.

[GEGridSolutions.com](http://GEGridSolutions.com)

ITL\_Model\_JVW\_4A-Spec-EN-2019-04-Grid-AIS-1518. © Copyright 2019. General Electric Company and Instrument Transformers LLC reserve the right to change specifications of described products at any time without notice and without obligation to notify any person of such changes.

#### Worldwide Contact Center

Web: [www.GEGridSolutions.com/contact](http://www.GEGridSolutions.com/contact)

Phone: +44 (0) 1785 250 070

USA and Canada: +1 (0) 800 547 8629

Europe, Middle East and Africa: +34 (0) 94 485 88 00

