

Model JVS-250 SUPERBUTE™

Outdoor Voltage Transformer
46,000 V, 60 Hz, 250 kV BIL

Application

Model JVS-250 is a single-bushing inductive voltage transformer designed for substation installation and is suitable for operating meters, instruments, relays, and control devices. JVS-250 is rated Station Class with higher burden, thermal rating, and creep distance. Additional designs are available upon request.

Features

- Insulation: HY-BUTE 60™ Butyl Rubber
- Insulation Class: 250 kV BIL, Outdoor
- Primary Winding Style: Lattice-Type
- Weight [Shipping/Net]: 480/420 lbs
- Accuracy Class & Burden: 0.3ZZ, all models
- Creep Distance: 48" [1219 mm]
- Design Standard: IEEE C57.13



JVS-250

Rated Primary Voltage (V)	Nominal System Voltage (V)	Ratio (Pri:Sec)	Thermal Rating 30 °C Amb.	Catalog Number
27,600	46,000	240/400 & 240/400:1	5,000 VA ³	768x030002 ⁴

Notes:

- (1) Designed for operation line-to-ground only, on grounded systems. If it should become necessary to apply to systems which are ungrounded or provided through high impedance, contact GE for analysis.
- (2) These voltage transformers are capable of operating at 173 % of rated voltage for one minute without exceeding 175 °C temperature rise.
- (3) To achieve 5,000 VA when using a 67.08 volt tap, loading must not exceed 3,000 VA on the 67.08 volt tap. If all load is on one 67.08 volt tap, thermal rating is 4,000 VA.
- (4) Measurement Canada Approval: T-0118



Advanced, Rugged Construction

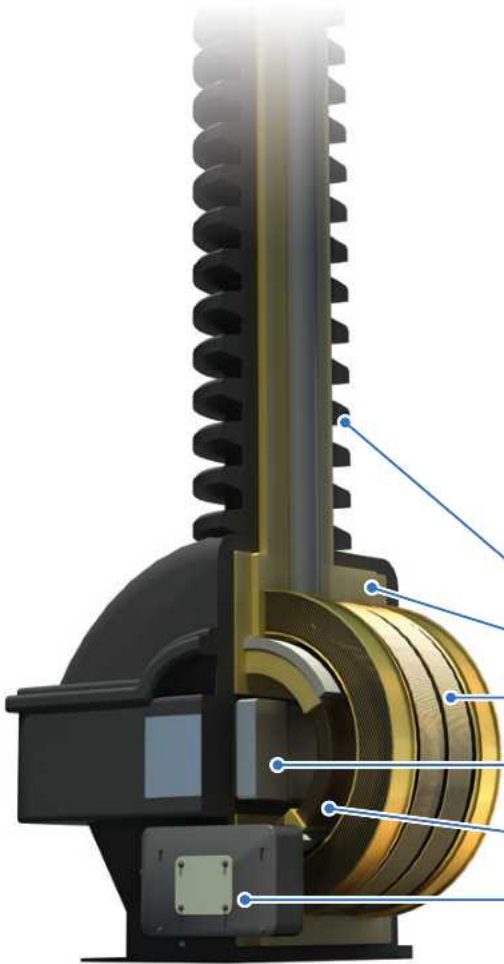

Tough & Resilient butyl rubber

First introduced in 1955, HY-BUTE 60™ is GE's unique butyl rubber formula. This material is hydrophobic, non-arc tracking, resistant to heat, chemicals, ozone and ultraviolet and is an elastic rubber which does not easily chip or crack. Use of HY-BUTE 60 enhances safety by increasing the likelihood of a passive, contained failure mode.

Superior Primary Windings

Originally patented by GE, lattice-type windings have precise controlled positioning and distribution of each turn to reduce maximum voltage stress within the winding. This unique design also minimizes the possibility of partial discharges within the winding. The coil configuration, and the outer electrostatic shields distribute steep voltage fronts across the coil to reduce concentration of stress. For additional dielectric and mechanical strength, coils are precast with epoxy resin prior to being molded with the HYBUTE 60™ outer shell.

- Butyl Rubber Shell
- Cycloaliphatic Epoxy
- Lattice-Tye Primary Winding
- Core
- Secondary Coil
- Secondary Terminal

Cross-Section view of a Station-Class SUPERBUTE Voltage Transformer

Secondary Terminal & Wiring Diagrams

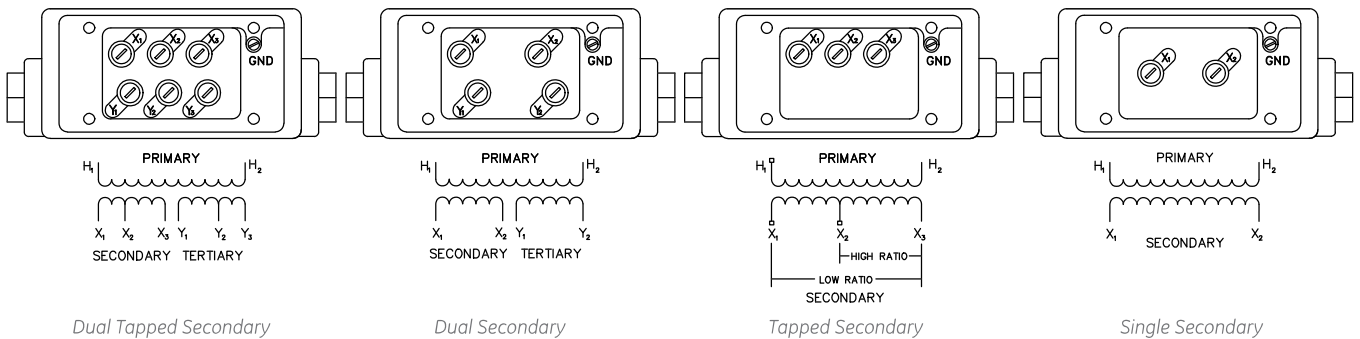

Dual Tapped Secondary

Dual Secondary

Tapped Secondary

Single Secondary

Outline Dimensions

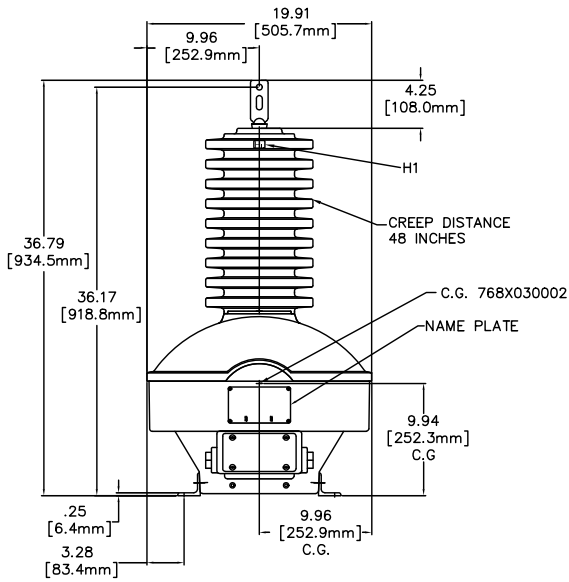

Front View

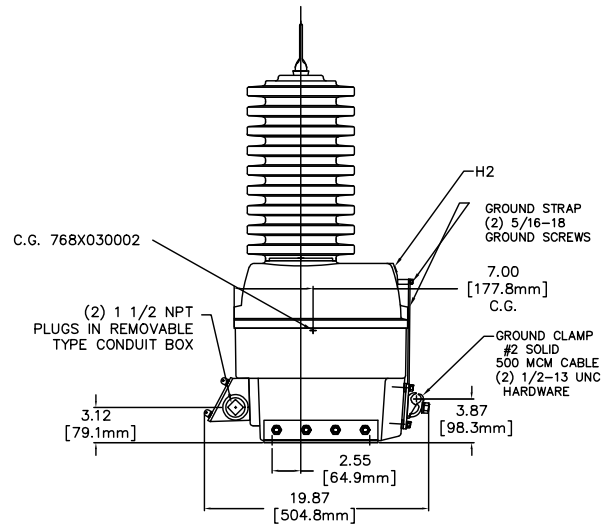

Side View

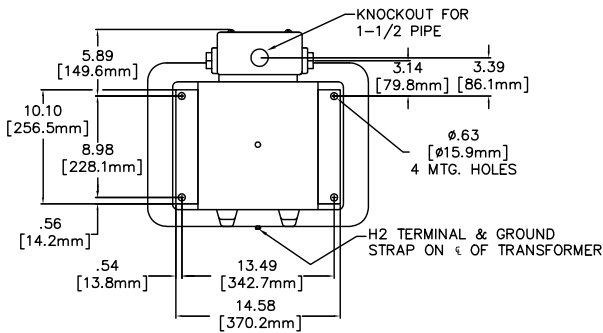

Bottom View

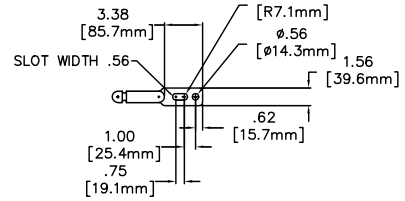

Primary Terminal

Typical Nameplate

Voltage Transformer		Type JVS-250	
Pri Volts 46000 GrdY / 27600 Ratio 240 / 400 & 240 / 400:1		Bil 250 kV 60 Hz	
Acc. Cl 0.3 W, X, M, Y, Z, ZZ 5.0 kVA @ 30C AMB		X1 - X3 = 115 Volts X2 - X3 = 69 Volts Y1 - Y3 = 115 Volts V2 - V3 = 69 Volts	
Caution: Read GEH-230 General Electric Co. Somersworth, NH USA		Ser. 7530243 Mfd. 12 14 Wt. 420 Lbs.	
Cat. 768X030002 Appr. T - 0118			

Construction Details

Insulation

The transformer design is constructed using GE's premium HY-BUTE 60™ molded butyl rubber insulation for the transformer body. First introduced in 1955, GE's unique formulation is non-arc tracking and resistant to heat, chemicals, ozone and ultraviolet. This tough, resilient insulating material has proven to be superior in handling mechanical, electrical and environmental extremes, when compared against other insulation designs such as porcelain, urethane or epoxy

Core & Coil

The internal primary windings are constructed with GE patented LATTICE winding style, which better distributes voltage stress across the windings, minimizes partial discharge, and maintains accuracy as compared to a layer wound primary design. Outer electrostatic faraday shields act to further distribute steep voltage fronts across the coils. The finished primary coil is precast in epoxy resin prior to being molded in the outer HY-BUTE 60™ insulation, for additional dielectric and mechanical strength. Enamelinsulated wire is used in both the primary and secondary coils. The cores are made from high quality silicon steel which is carefully selected, tested, and annealed under rigidly controlled factory conditions. Each core is a shell type of laced construction. They are assembled and supported on flanges that form part of the base structure. The cores are tightly banded in place and protected from weathering by the transformer casing.

Bushing

Since the bushings are an integral part of the transformer, standards normally pertaining to porcelain bushing tests do not apply. However, characteristics equal to, or better than, those required for porcelain are provided.

Primary Terminals

The primary terminal consists of a copper or cast bronze, NEMA-approved, flat, two-hole pad. The complete terminals are heavily tin-electroplated for use with either copper or aluminum conductors. This construction can be easily adapted to any type of line termination by use of any of a variety of commercially available connectors.

Secondary Terminals

The secondary terminals are of the screw-type construction (1/4-20 UNC) with binding heads for making connection to spade-type or bare conductors. Each end of the secondary winding is brazed to a threaded sleeve which projects through the resin to provide a solid brass surface to which a spadetype connection can be made. The secondary terminals are enclosed in a conduit box, secured to the base of the transformer with four 1/4-20 screws.

Testing

Rigorous GE test requirements go beyond ANSI/IEEE routine requirements in order to ensure long term reliability. Test reports are saved electronically and can be e-mailed in various formats upon request.

Ground Terminal

The clamp-type ground connector is for use with No. 2 solid to 500 MCM copper or aluminum grounding cable.

Conduit Box

The terminal box has 1 1/2 inch threaded conduit openings at each end, and a 1 1/2 inch knockout at the bottom. It is also provided with a secondary circuit grounding terminal.

Polarity

The permanently molded primary polarity markings H1 and H2 and the secondary polarity markings X1 and X2 are situated adjacent to their respective terminals. The polarity terminal is designated by use of the subscript 1, and the mark is painted white for better visibility

Baseplate and Mounting

SUPERBUTE voltage transformers and current transformers can be mounted in any position from upright to inverted, providing the centerline of current transformers through the primary terminals is parallel with the ground surface. Loading by lines or busswork on either VT's or CT's should be kept to a maximum to avoid placing appreciable strain upon the transformer bushings and terminals. For CT's, the maximum recommended loading from all sources should not be greater than the equivalent of a 200-pound external force applied at the axis of the primary terminals. The base assembly is made of cast aluminum. All exposed metallic surfaces are protected with two coats of baked enamel. The base framework supports the core and windings, and contains a grounding pad and provision for mounting the detachable secondary terminal box.

Nameplate

The nameplate is made of stainless-steel and located on the base of the transformer. Information is per IEEE designation, laser-engraved for easy- to-read form. Custom barcoding available upon request.

Maintenance

These transformers require no maintenance other than an occasional cleaning if installed in an area where air contamination is severe.

GEGridSolutions.com

ITI-Model-JVS-250-Spec-EN-2017-11-Grid-AIS-1507. © Copyright 2017. General Electric Company and Instrument Transformers LLC reserve the right to change specifications of described products at any time without notice and without obligation to notify any person of such changes.

Worldwide Contact Center

Web: www.GEGridSolutions.com/contact

Phone: +44 (0) 1785 250 070

USA and Canada: +1 (0) 800 547 8629

Europe, Middle East and Africa: +34 (0) 94 485 88 00

