

# 219 Series - Industrial Relays

## DPDT, up to 6PST, 10 Amps



Versatile. Rugged. Proven. These are but a few words used by customers to describe the 219 series. When long life and cost of down time / service are important the 219 solves the problem. It's a standard throughout industrial applications which many other relays are measured against. Capable of up to four poles double throw or six poles single throw. Contact arrangements are easily customized for special applications. NUCLEAR versions are available that utilize special platings and materials to minimize wear. All 219s are built with materials that meet the UL 94-V0 requirements.

### GENERAL SPECIFICATIONS (@ 25° C)

#### Contacts:

Contact Configuration	Up to 4PDT or 6PST
Contact Material	Silver Alloy-Gold Diffused
Contact Rating	10 Amp / 5 Amp
120 / 240VAC Resistive	10 Amp
28VDC Resistive	5 Amp
Contact Resistance, Initial	50 milliohms max @ 6vdc

#### Coil:

Coils Available	AC and DC
Nominal Coil Power	AC 5VA DC 1.8-2.5W
Input Voltage Tolerance - AC	85% to 110% of nominal
Input Voltage Tolerance - DC	80% to 110% of nominal
Drop-out voltage	10% of nominal
Duty	Continuous

#### Timing:

Operate Time (max)	25 mS
Release Time (max)	20 mS

#### Dielectric Strength:

Across Open Contacts	500Vrms
Between mutually insulated point	1500Vrms
Insulation resistance	1,000 Mohms min @ 500VDC

#### Temperature:

Operating	AC = -20 to 60°C (-4 to 140°F) DC = -20 to 70°C (-4 to 158°F)
Storage	-40 to 105°C (-40 to 221°F)

#### Life Expectancy:

Electrical (full load)	100,000
Mechanical (no load)	10,000,000

#### Miscellaneous:

Mounting Position	Any
Enclosure	Clear Polycarbonate
Weight	8.5oz (241 grams)
Mating socket	12 PIN: 27390 (D)
(UL Listed when used)	14 PIN: 33377 (D)
	(D) is option for DIN Rail Mount



# General Purpose Relays

**Ordering Code**    **219**    **XBX**    **PL**    **-24VDC**

**Series**  
219

**Contact Arrangement**

- XBX (DPDT)
- ABA (1 Pole N.O. + DPDT + 1 Pole N.C.)
- BBX (2 Pole NO & DPDT)
- XDX (4PDT)
- FXX (6 Pole-NO)
- DXB (4 Pole - NO & 2 Pole-NC)

**Optional Features**

- Permanent Magnet Blowout - CODE 69
- Polycarbonate covers - CODE P
- Indicator Lamp - CODE L
- Manual Actuator - CODE M
- Bifurcated Contacts - CODE 33

**Coil Voltage**

- AC: 12, 24, 120, 240, (Add VAC)
- DC: 6, 12, 24/28, 32, 48, 115/125, 250 (Add VDC)

Coil voltages and frequencies must be specified

## Contact Load Ratings

### Highest Load for Standard Contacts

(Current - A, Resistive unless otherwise noted)

Voltage	Make	Carry	Break
28 VDC, "69"	10A		
		10A	
	10A		
48 VDC, "69"	10A		
		5A	
	5A		
125 VDC, "69"	10A		
		4A	
	3A		
250 VDC, "69"	4A		
		2A	
	1A		
120 VAC	10A*, 3A Inductive, 1/6HP*		
		10A*, 3A Inductive, 1/6HP*	
	10A*, 3A Inductive, 1/6HP*		
240 VAC	10A, 5A*, 1/3HP*		
		10A, 5A*, 1/3HP*	
	10A, 5A*, 1/3HP*		
277 VAC	10A		
		7A	
	4.5A		

Contact ratings which include an "\*" are UL Approved.

Use Code "69" for blowout magnet when switching voltages above 40VDC. (NOT UL OR CSA APPROVED)

Use Code "33" for bifurcated contacts when switching low level current below 50mA.

## 219 Coil Specifications

AC Coils, 50/60HZ					DC Coils			
Nominal voltage	Resistance ohms ±10%	Milliamperes Cold Hot		Impedance ohms	Nominal voltage	Resistance ohms ±10%	Milliamperes Cold Hot	
6	1.1	1500	840	7.2	6	15.5	385	304
12	4.2	750	410	27	12	63.5	189	147
24	15.5	375	200	120	24 /28*	250	96	77
120	540	75	40	2,700	32	375	86	62
240	2100	32	17	13,400	37.5	375	100	80
					48	975	49	39
					115/125*	6200	20	16
					250	27777	9	7

Note: Stock 24VDC and 115VDC relays have nameplates stamped 24/28VDC and 115/125VDC respectively. These relays operate at 80% of the lower voltages and operate within allowable temperature rises at higher voltages.

# General Purpose Relays

## Additional Contact Ratings

### Lowest Load for Standard Contacts

(Current - A, Resistive unless otherwise noted)

Voltage	Make	Carry	Break
5 VDC	1A		
		1A	
			1A
12 VDC	0.75A		
		0.75A	
			0.75A
28 VDC	0.050A		
		0.050A	
			0.050A
48 VDC	0.050A		
		0.050A	
			0.050A
125VDC	0.050A		
		0.050A	
			0.050A
250 VDC	0.050A		
		0.050A	
			0.050A
120 VAC	0.050A		
		0.050A	
			0.050A
240 VAC	0.050A		
		0.050A	
			0.050A
480 VAC	0.050A		
		0.050A	
			0.050A

### Highest Load for Bifurcated Contacts

(Current - A, Resistive unless otherwise noted)

Voltage	Make	Carry	Break
28 VDC	5A		
		3A	
			2.5A
48 VDC	3A		
		2A	
			1.5A
125VDC	1A		
		0.5A	
			0.25A
250 VDC	0.5A		
		0.25A	
			0.1A
120 VAC	5A*		
		5A*	
			5A*
240 VAC	2.5A*		
		2.5A*	
			2.5A*
277 VAC	2.5A		
		1.5A	
			1.0A
480 VAC	0.5A		
		0.2A	
			0.2A

### Lowest Load for Bifurcated Contacts

(Current - A, Resistive unless otherwise noted)

Voltage	Make	Carry	Break
5 VDC	0.1A		
		0.1A	
			0.1A
12 VDC	0.075A		
		0.075A	
			0.075A
28 VDC	0.01A		
		0.01A	
			0.01A
48 VDC	0.005A		
		0.005A	
			0.005A
125VDC	0.005A		
		0.005A	
			0.005A
250 VDC	0.001A		
		0.001A	
			0.001A
120 VAC	0.01A		
		0.01A	
			0.01A
240 VAC	0.005A		
		0.005A	
			0.005A
480 VAC	0.001A		
		0.001A	
			0.001A

Contact ratings which include an “\*” are UL Approved.

Use Code “69” for blowout magnet when switching voltages above 40VDC. (NOT UL OR CSA APPROVED)

Use Code “33” for bifurcated contacts when switching low level current below 50mA.

# 219 Series - Industrial Relays

## DPDT, Up To 6PST, 10 Amps

### Outline Dimensions

Dimensions Shown in inches & (millimeters)

#### 12 Pin Plug-in

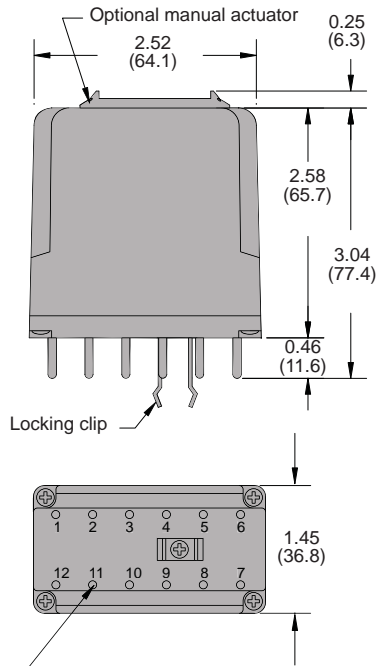

.10 x .43 (2.5 x 11.0) DIA. Typical of all pin dimensions

#### 14 Pin Plug-in

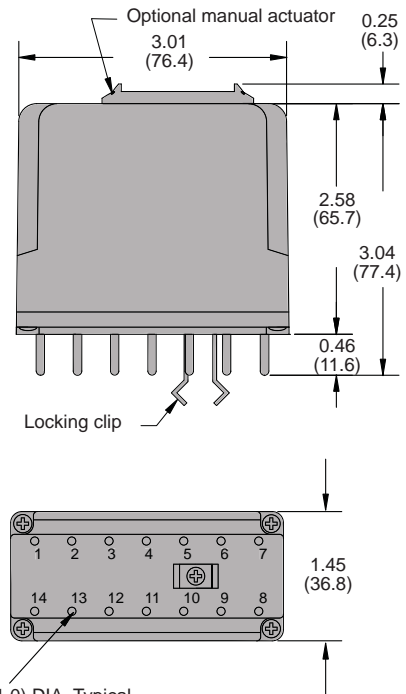

.10 x .43 (2.5 x 11.0) DIA. Typical of all pin dimensions

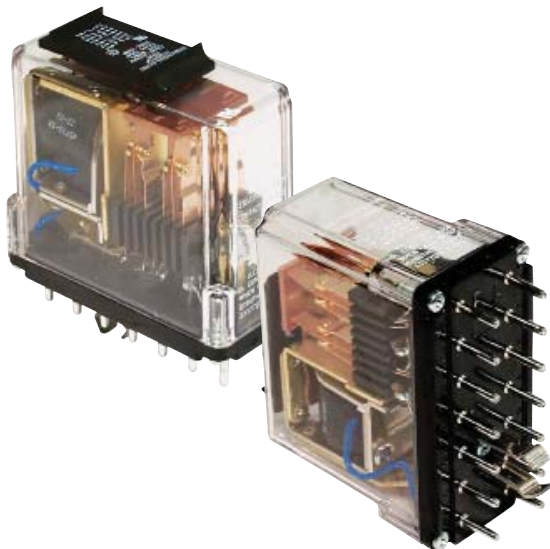

# General Purpose Relays

## 219 Wire Diagram (Top View) 12-Pin

**219ABX**  
(SPST-N.O. + DPDT)

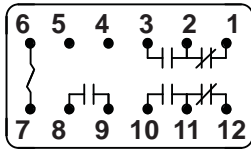

**219ABA**  
(DPDT+SP-NO+1P-NC)

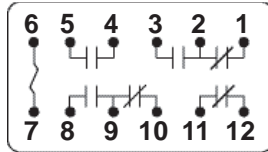

**219BBX**  
(DPDT+2P- N.O.)

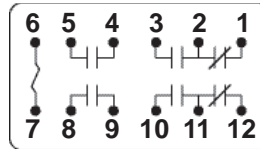

**219BXB**  
(DPDT+2P- N.O.)

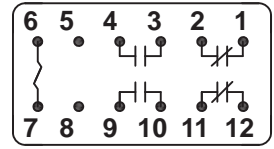

**219XBX**  
(DPDT)

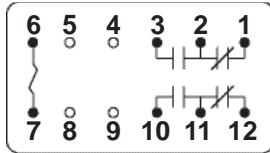

**219XCX**  
(3PDT)

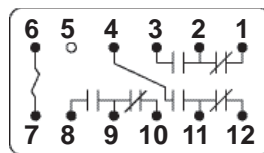

Many additional contact combinations and wiring schematics are available. Contact sales with requirements.

### Standard Diode Suppression Wiring

(applies to relays with option "V", alternative polarity/wiring is also available as a special)

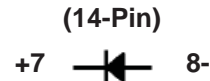
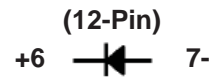

## 219 Wire Diagram (Top View) 14-Pin

**219BXD**  
(2P-NO+4P-NC)

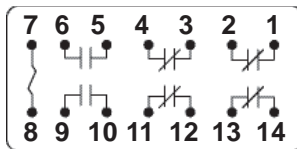

**219CXC**  
(3P-NO+3P-NC)

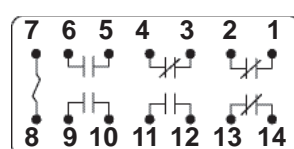

**219DXB**  
(4P-NO+2P-NC)

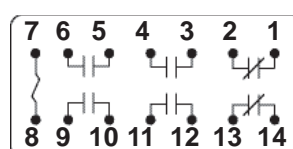

**219EXA**  
(5P-NO+1P-NC)

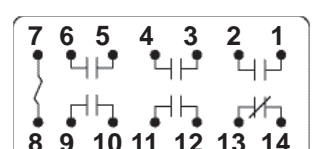

**219FXX**  
(6P-NO)

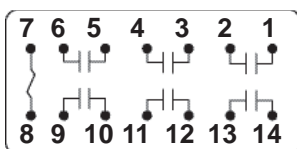

**219KXX**  
(3PST-DM)

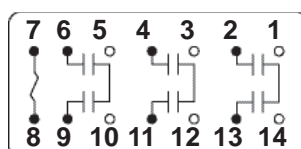

**219XDX**  
(4PDT)

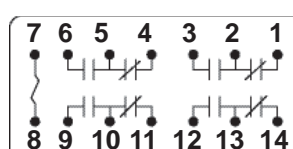

**219XJX**  
(DPDT-DM/DB)

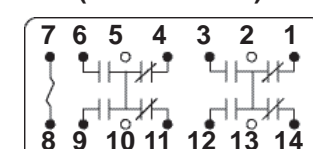

UL LISTED when used with mating sockets  
27390 for 12 pin or 33377 for 14 pin